

# DC Axial Fans



## YD42X05L(M)(H) YD42X12L(M)(H) YD42X24L(M)(H)

### Features

Size: 40×40×20mm(1.57×1.57×0.79in)

Frame/Impeller: Reinforced Plastic UL94V-0

Bearings: Ball Bearing&Sleeve Bearing

Life Expectancy:50,000 Hours at 20°C -Ball  
30,000 Hours at 20°C-Sleeve

Approvals: UL CUL TUV CE RoHS

Weight: 25g

E318377 CE TUV AE50078959

▪ RoHS Compliant

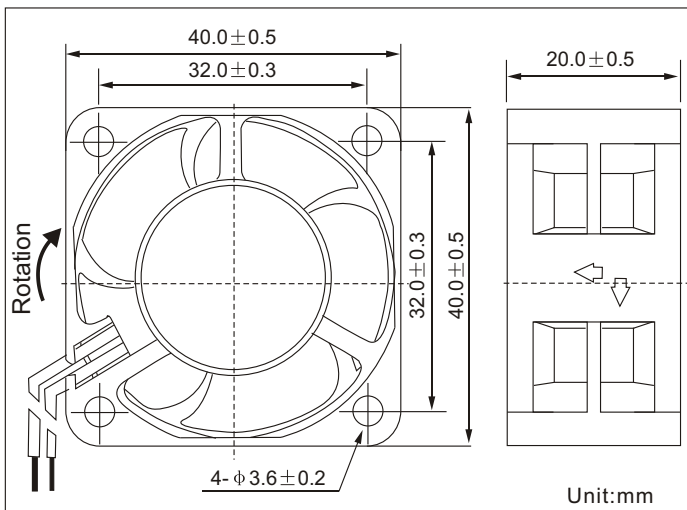

### Air Flow vs Air Pressure

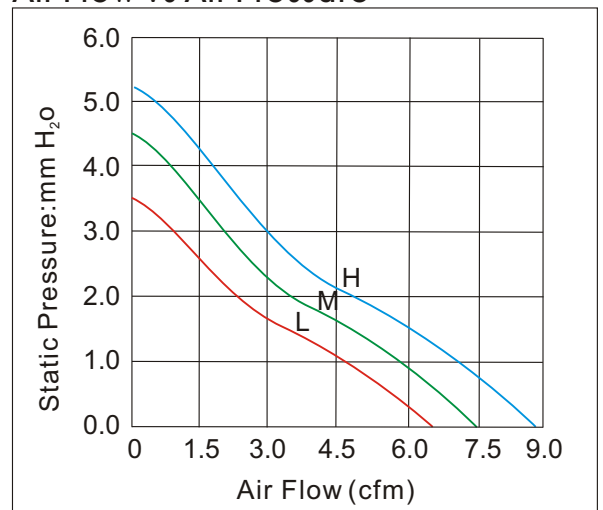

### Performance

Model	Bearing System X			Rated Voltage (V)	Current (A)	Input Power (W)	Nominal Speed (R.P.M)	Air Flow (CFM)	Air Pressure (mm-H <sub>2</sub> O)	Noise (dBA)
	S	B	D							
YD42X05L	✓	✓	✓	5	0.12	0.60	5500	6.42	3.52	26
YD42X05M	✓	✓	✓	5	0.15	0.75	6500	7.45	4.50	28
YD42X05H	✓	✓	✓	5	0.20	1.00	7500	8.85	5.25	30
YD42X12L	✓	✓	✓	12	0.06	0.72	5500	6.42	3.52	28
YD42X12M	✓	✓	✓	12	0.08	0.96	6500	7.45	4.50	28
YD42X12H	✓	✓	✓	12	0.10	1.20	7500	8.85	5.25	30
YD42X24L	✓	✓	✓	24	0.05	1.20	5500	6.42	3.52	26
YD42X24M	✓	✓	✓	24	0.06	1.44	6500	7.45	4.50	28
YD42X24H	✓	✓	✓	24	0.07	1.68	7500	8.85	5.25	30