

# DC Axial Fans



## YD13X12L(M)(H) YD13X24L(M)(H) YD13X48L(M)(H)

### Features

Size: 120×120×38mm(4.72×4.72×1.50in)

Frame/Impeller: Reinforced Plastic UL94V-0

Bearings: Ball Bearing&Sleeve Bearing

Life Expectancy: 50,000 Hours at 20°C-Ball  
30,000 Hours at 20°C-Sleeve

Approvals: UL CUL TUV CE RoHS

Weight: 250g

E318377 CE TUV AE50078978

▪ RoHS Compliant

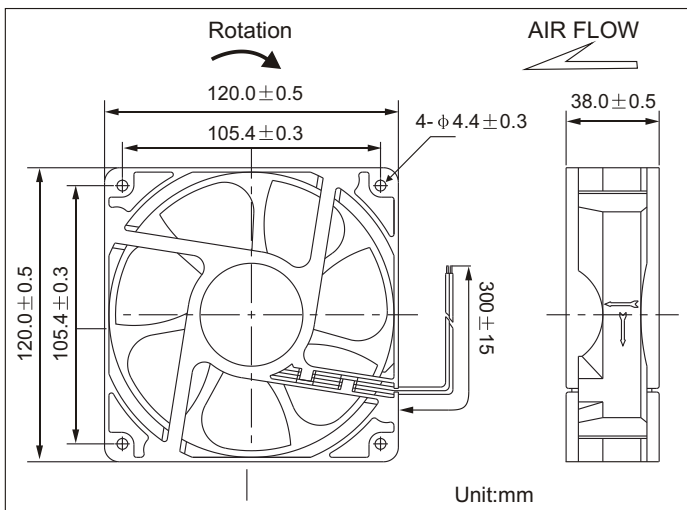

### Air Flow vs Air Pressure

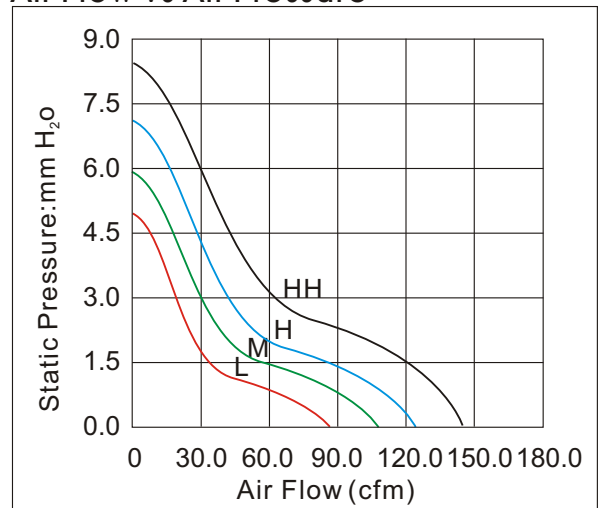

### Performance

Model	Bearing System X			Rated Voltage (V)	Current (A)	Input Power (W)	Nominal Speed (R.P.M)	Air Flow (CFM)	Air Pressure (mm-H <sub>2</sub> O)	Noise (dBA)
	S	B	D							
YD13X12L	✓	✓	✓	12	0.25	3.00	2000	85.56	4.83	37
YD13X12M	✓	✓	✓	12	0.35	4.20	2500	102.14	5.95	42
YD13X12H	✓	✓	✓	12	0.55	6.60	3000	125.06	7.15	47
YD13X12HH	✓	✓	✓	12	0.70	8.40	3500	148.66	8.21	52
YD13X24L	✓	✓	✓	24	0.20	4.80	2000	85.56	4.83	37
YD13X24M	✓	✓	✓	24	0.30	7.20	2500	102.14	5.95	42
YD13X24H	✓	✓	✓	24	0.40	9.60	3000	125.06	7.15	47
YD13X24HH	✓	✓	✓	24	0.50	12.00	3500	148.66	8.21	52
YD13X48M	✓	✓	✓	48	0.12	5.76	2500	102.14	5.95	42
YD13X48H	✓	✓	✓	48	0.20	9.60	3500	148.66	8.21	52