

# AC Axial Fans



## YA8038HA1 YA8038HA2

### Features

Size: 80×80×38mm(3.15×3.15×1.5in)

Frame: Aluminum Painted&Plastic UL94V-0

Impeller: Reinforced Plastic UL94V-0

Bearings: Ball Bearing&Sleeve Bearing

Life Expectancy:50,000 Hours at 20°C-Ball

30,000 Hours at 20°C-Sleeve

Approvals: UL CUL CE 3C RoHS

Weight: 350g

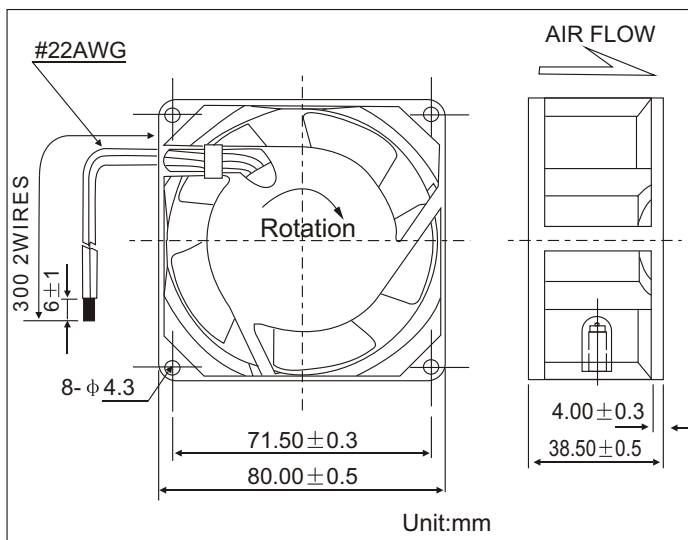

### Air Flow vs Air Pressure

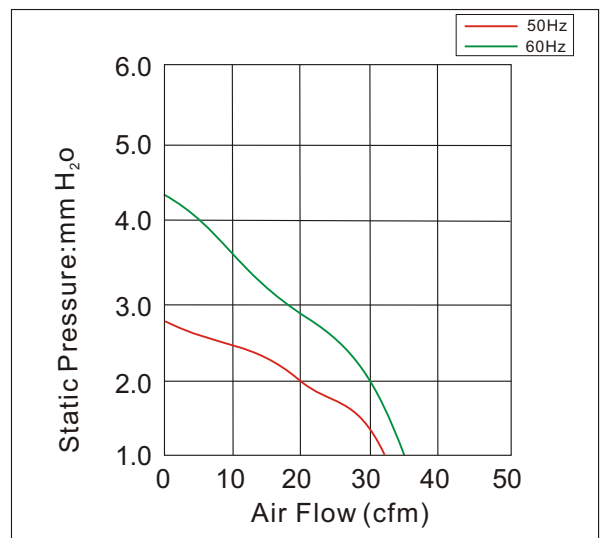

### Performance

Model	Part Number	Bearing System	Rated Voltage (V)	Operating Frequency (Hz)	Current (A)	Input Power (W)	Nominal Speed (R.P.M)	Air Flow (CFM)	Air Pressure (mm-H <sub>2</sub> O)	Noise (dBA)
YA8038HA1	YA8038HA1SL(T)	Sleeve or	110/120	50/60	0.12/0.15	11/15	2300/2800	32/35	2.80/4.32	30/35
	YA8038HA1BL(T)	Ball								
YA8038HA2	YA8038HA2SL(T)	Sleeve or	220/240	50/60	0.10/0.09	14/13	2300/2800	32/35	2.80/4.32	30/35
	YA8038HA2BL(T)	Ball								