

AC Axial Fans



YA11025HA1 YA11025HA2

Features

Size: 110×110×25mm(4.33×4.33×1.0in)

Frame: Aluminum Painted&Plasic UL94V-0

Impeller: Reinforced Plastic UL94V-0

Bearings: Ball Bearing&Sleeve Bearing

Life Expectancy:50,000 Hours at 20°C-Ball
30,000 Hours at 20°C-Sleeve

Approvals: UL CUL CE 3C RoHS

Weight: 300g

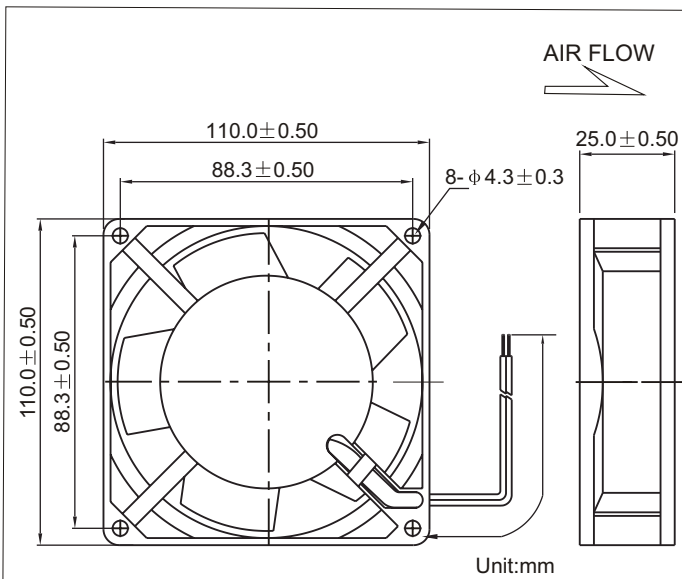

Air Flow vs Air Pressure

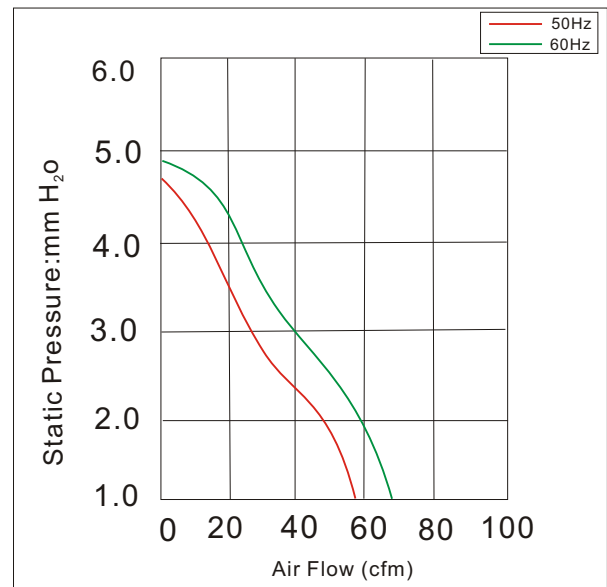

Performance

Model	Part Number	Bearing System	Rated Voltage (V)	Operating Frequency (Hz)	Current (A)	Input Power (W)	Nominal Speed (R.P.M)	Air Flow (CFM)	Air Pressure (mm-H ₂ O)	Noise (dBA)
YA11025HA1	YA11025HA1SL YA11025HA1BL	Sleeve or Ball	110/120	50/60	0.10/0.12	18/17	2300/2700	58/68	4.80/4.90	36/38
YA11025HA2	YA11025HA2SL YA11025HA2BL	Sleeve or Ball	220/240	50/60	0.07/0.08	18/17	2300/2700	58/68	4.80/4.90	36/38